

INSTRUCTION MANUAL

BS-5

**Metal Cutting Band Saw (240V)
150 x 115mm (W x H) Rectangle**



B009

 **WARNING!**

Some dust created by power sanding, sawing, grinding, drilling, and other construction activities contains chemicals known to the State of California to cause cancer, birth defects or other reproduce harm. Some examples of these chemical are:

- Lead from lead-based paints.
- Crystalline silica from bricks, cement and other masonry products.
- Arsenic and chromium from chemically-treated lumber.

Your risk from these exposures varies, depending on how often you do this type of work. To reduce your exposure to these chemicals: Work in a well ventilated area, and work with approved safety equipment, such as those dust masks that are specially designed to filter out microscopic particles.

"THIS MACHINE IS FOR METAL CUTTING ONLY, IT IS NOT APPROVED FOR CUTTING WOOD. THE SUPPLIER ACCEPTS NO RESPONSIBILITY FOR ANY MACHINE WHEN USED FOR CUTTING WOOD. "

- A. Average Noise Level=continuous level of airborne noise from machines when running at full speed with no load.**
- C. Loudest Noise level=the peak noise level recorded from machines when running at full speed with no load.**

Based on above two measurements A & C. this band-saw's equivalent A-weighted sound pressure level at the work station was measured at 70 dB, while its peak C-weighted instantaneous sound pressure value at the work station was measured at 75 dB.

(FOR CE MACHINE ONLY)

CAUTION :

VERTICAL CUTTING IS PROHIBITED IN THE MACHINE. NO VERTICAL CUTTING PLATE PROVIDED, TO PREVENT ANY IMPROPER USE.

Table Of Contents	Page No
1 Overall Aspect	4
2 Safety rules for all tools	5
3 Specification	8
4 Features	8
5 Delivery & Installation	8
6 Minimum Room Space For Machine Operation	11
7 Operation	11
8 Machine elements adjustment.....	14
9 Maintaining	16
10 Lubricating	16
11 Trouble Shooting	17
12 Circuit Diagram	19
13 Parts Drawing	21
14 Parts List	26

MACHINERYHOUSE

1.Overall Aspect

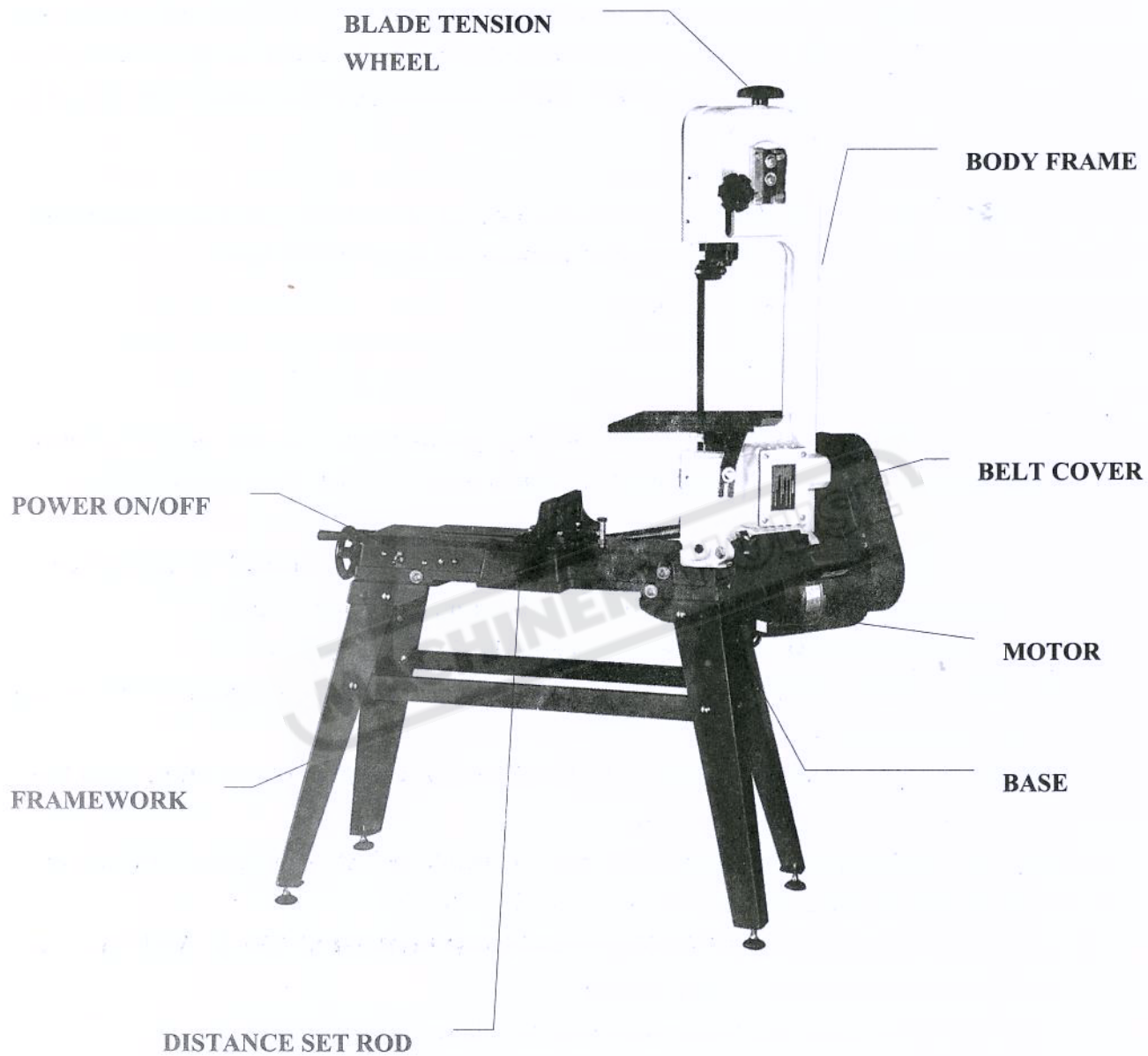

**WARNING: FAILURE TO FOLLOW THESE RULES
MAY RESULT IN SERIOUS PERSONAL INJURY**

As with all machinery there are certain hazards involved with operation and use of the machine. Using the machine with respect and caution will considerably lessen the possibility of personal injury. However, if normal safety precautions are overlooked or ignored, personal injury to the operator may result.

This machine was designed for certain applications only. We strongly recommends that this machine NOT be modified and/or used for any application other than for which it was designed. If you have any questions relative to its application DO NOT use the machine until you contact with us and we have advised you.

Your machine might not come with a power socket or plug. Before using this machine, please Do ask your local dealer to install the socket or plug on the power cable end.

2.SAFETY RULES FOR ALL TOOLS

A. USER:

(1). **WEAR PROPER APPAREL.** No loose clothing, gloves, rings, bracelets, or other jewelry to get caught in moving parts.

Non-slip foot wear is recommended. Wear protective hair covering to contain long hair.

(2). **ALWAYS WEAR EYE PROTECTION.** Refer to ANSLZ87.1 standard for appropriate recommendations.

Also use face or dust mask if cutting operation is dusty.

(3). **DON'T OVERREACH.** Keep proper footing and balance at all times.

(4). **NEVER STAND ON TOOL.** Serious injury could occur if the tool is tipped or if the cutting tool is accidentally contacted.

(5). **NEVER LEAVE TOOL RUNNING UNATTENDED. TURN POWER OFF.** Don't leave tool until it comes to a complete stop.

(6). **DRUGS, ALCOHOL, MEDICATION.** Do not operate tool while under the influence of drug, alcohol or any medication.

(7). **MAKE SURE TOOL IS DISCONNECTED FROM POWER SUPPLY.** While motor is being mounted, connected or reconnected.

(8). **ALWAYS** keep hands and fingers away from the blade.

(9). **STOP** the machine before removing chips.

(10). **SHUT- OFF** power and clean the BAND SAW and work area before leaving the machine.

B. USE OF MACHINE:

(1). **REMOVE ADJUSTING KEYS AND WRENCHES.** Form habit of checking to see that keys and adjusting wrenches are removed from tool before turning it "on".

- (2). **DON'T FORCE TOOL.** It will do the job better and be safer at the rate for which it was designed.
- (3). **USE RIGHT TOOL.** Don't force tool or attachment to do a job for which it was not designed.
- (4). **SECURE WORK.** Use clamps or a vise to hold work when practical. It's safer than using your hand frees both hands to operate tool.
- (5). **MAINTAIN TOOLS IN TOP CONDITION.** Keep tools sharp and clean for best and safest performance. Follow instructions for lubricating and changing accessories.
- (6). **USE RECOMMENDED ACCESSORIES.** Consult the owner's manual for recommended accessories. The use of improper accessories may cause hazards.
- (7). **AVOID ACCIDENTAL STARTING.** Make sure switch is in "OFF" position before plugging in power cord.
- (8). **DIRECTION OF FEED.** Feed work into a blade or cutter against the direction of rotation of the blade or cutter only.
- (9). **ADJUST AND POSITION** the blade guide arm before starting the cut.
- (10). **KEEP BLADE GUIDE ARM TIGHT,** A loose blade guide arm all affect sawing accuracy .
- (11). **MAKE SURE** blade speed is set correctly for material being cut.
- (12). **CHECK** for proper blade size and type.
- (13). **STOP** the machine before putting material in the vise.
- (14). **ALWAYS** have stock firmly clamped in vise before starting cut.
- (15). **GROUND ALL TOOLS.** If tool is equipped with three-prong plug, it should be plugged into a three-hole electrical receptacle. If an adapter is used to accommodate two-prong receptacle, the adapter lug must be attached to a known ground. Never removed the third prong.

C. ADJUSTMENT :

MAKE all adjustments with the power off. In order to obtain the machine. precision and correct ways of adjustment while assembling, the user should read the detailed instruction in this manual.

D. WORKING ENVIRONMENT:

- (1). **KEEP WORK AREA CLEAN.** Cluttered areas and benches invite accidents.
- (2). **DON'T USE IN DANGEROUS ENVIRONMENT.** Don't use power tools in damp or wet locations, or expose them to rain. Keep work area well-lighted.
- (3). **KEEP CHILDREN AND VISITORS AWAY.** All children and visitors should be kept a safe distance from work area.
- (4). **DON'T** install & use this machine in explosive, dangerous environment.

E. MAINTENANCE:

- (1). **DISCONNECT** machine from power source when making repairs.
- (2). **CHECK DAMAGED PARTS**. Before further use of the tool, a guard or other part that is damaged should be carefully checked to ensure that it will operate properly and perform its intended function check for alignment of moving parts, binding of moving parts, breakage of parts, mounting, and any other conditions that may affect its operation. A guard or other part that is damaged should be properly repaired or replaced.
- (3). **DISCONNECT TOOLS** before servicing and when changing accessories such as blades, bits, cutters, etc.
- (4). **MAKE SURE** that blade tension and blade tacking are properly adjusted.
- (5). **RE-CHECK** blade tension after initial cut with a new blade.
- (6). **TO RPOLONG BLADE LIFE ALWAYS** release blade tension at the end of each work day.
- (7). **CHECK COOLANT DAILY** Low coolant level can cause foaming and high blade temperatures. Dirty or week coolant can clog pump, cause crooked. Cust, low cutting rate and permanent blade failure. Dirty coolant can cause the growth of bacteria with ensuing skin irritation.
- (8). **WHEN CUTTING MAGNESIUM NEVER** use soluble oils or emulsions(oil-water mix) as water will greatly intensify any accidental magnesium chip fire. See your industrial coolant supplier for specific coolant recommendations when cutting magnesium.
- (9). **TO PRNMT** corrosion of machined surfaces when a soluble on is used as coolant, pay particular attention to wiping dry the surfaces where fluid accumulates and does not evaporate quickly, such as between the machine bed and vise.

F. SPECTIFIED USAGE:

This machine is used only for general metals cutting within the range of cutting capacity.

G. NOISE:

A weighted sound pressure level : 80 dB.

3.SPECIFICATIONS:

- | | |
|----------------------------|--|
| 1. Capacity | : 90° --○ =Ø5" (Ø 128mm)
--□ = 4-1/2" * 6" (115mm * 150mm)
: 45° --○ =Ø3" (Ø 76mm)
--□ = 3" * 4-1/2" (76mm * 115mm) |
| 2. Speeds | : 60HZ = 80-120-200 FPM (24-37-61 M.P.M)
: 50HZ = 65-95-165 FPM (20-29-50 M.P.M) |
| 3. Motor | : 1/3HP (1/2 HP) , 60HZ=1725RPM
50HZ=1420RPM |
| 4. Blades Size(W * T * L) | : 1/2" * 0.025" * 64 1/2"
(12.7mm * 0.64mm * 1635mm) |
| 5. Blade Wheels | : 7 3/8"(187mm) High strength flanged cast iron. |
| 6. Floor Model Dimensions | : Length -(1029mm)
: Width -(457mm)
: Height- (965mm) Cut/Off
: Height -(1378mm) Vertical |
| 7. Bench Model Dimensions | : Length -(1029mm)
: width -(457mm)
: Height -(591mm) Cut/Off
: Height -(851mm) Vertical |
| 8. N. W./G.W. | : 60 / 61 Kgs |
| 9. Packing (L * W * H) | : 38" x 13" x 16"(965mmx330mmx406mm) |
| 10. 20' Container Q'ty | : 249 sets(CE 190 sets) |

4.FEATURES

1. Special designed horizontal band saw.
2. Offers three speeds for cutting metal.
3. Shuts off automatically when material is cut.
4. With scale for the mitering vise.
5. No noise while operating.
6. Casters (optional) quick and easy moving.

5.DELIVERY & INSTALLATION

5-1.Unpacking

1. Transportation to desired location before unpacking, please use lifting jack.(Fig. B)

2. Transportation after unpacking, please use heavy duty fiber belt to lift up the machine.

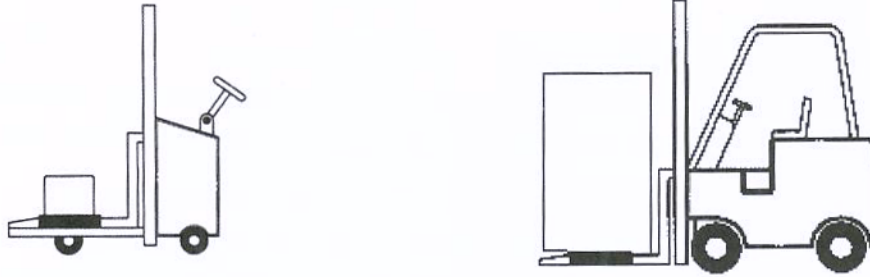

Fig. B

**ALLWAYS KEEP PROPER FOOTING & BALANCE WHILE MOVING THIS MACHINE
TRANSPORTATION OF MACHINE:**

As this machine weights 60kgs(135lbs) it is recommended that the machine be transported with help of lifting jack.

Transportation Recommendation:

1. Tighten all locks before operation.
2. **ALWAYS** Keep proper footing & balance while moving this machine, and only use heavy duty fiber belt to lift the machine.
3. **TURN OFF** the power before wiring & be sure machine is properly grounded.
Overload & circuit breaker are recommended for safety wiring.
4. **CHECK** carefully if the saw blade is running in counter-clockwise direction if not, reverse the wiring per circuit diagram then repeat the running test.
5. **KEEP** machine always out from sun, dust, wet or raining area.

5.2. Band Saw Installation

1. The saw may be mounted on your own bench, or stand using six bolts.
2. The rear end of the base must be mounted on the rear of the stand or bench to permit vertical operation for this band saw.
3. **KEEP** machine always out from sun, dust, wet, mining area .
4. **CHECK** carefully if the saw blade is running in counter-clockwise direction if not, reverse the wiring per circuit diagram then repeat the running test.
5. Tighten all locks before operation.

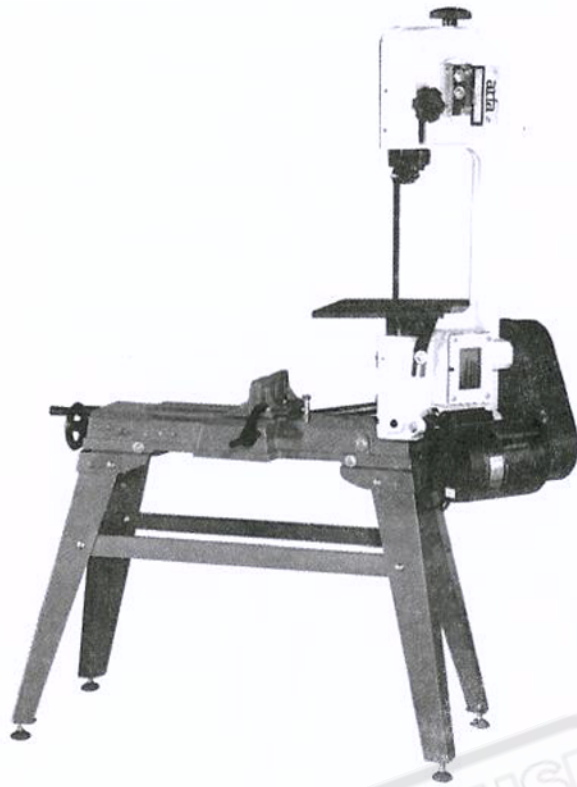

MACHINERYHOUSE

6. MINIMUM ROOM SPACE FOR MACHINE OPERATION

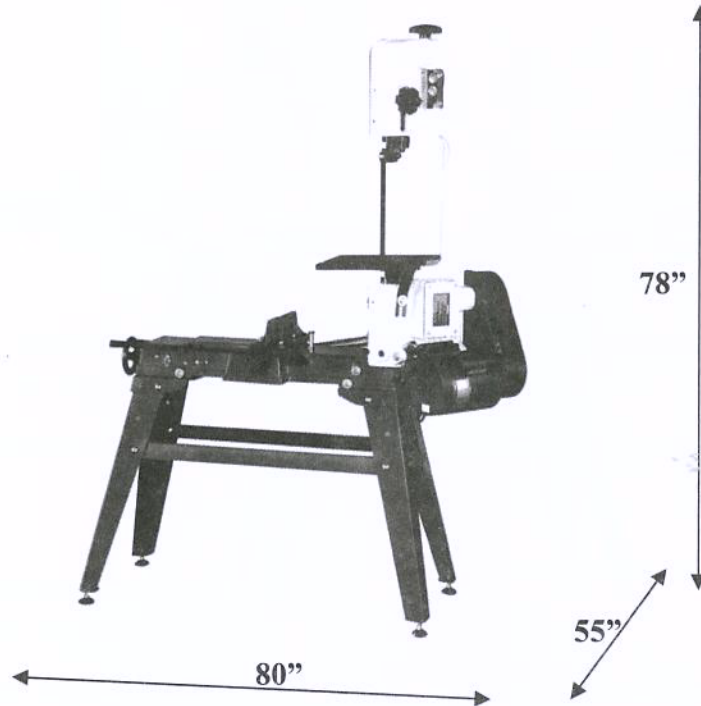

7. OPERATION

A Hexagon Head Screw should be adjusted in accurate height when machine in cutting and after finished off cutting then magnetic Switch can be lost.

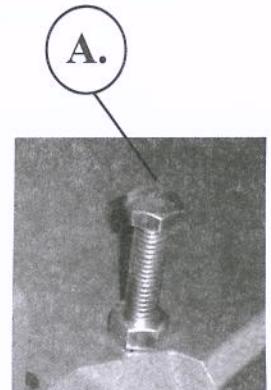

7-1. Operation Steps

- (1) Raise the saw head to vertical position.
- (2) Adjust the motor automatic stop key so the motor might stop just while the work-piece is cut off.
- (3) Adjust the stock stop to the desired length position.
- (4) Open vise to accept the work-piece to be cut. If the piece is long, support the end.
- (5) Rotate the hand wheel to tighten the work-piece.
- (6) Turn on the switch, and change the blade speed to best suit the work-piece being cut.
- (7) Let the saw head down slowly to touch the work-piece lest the blade should be broken by excessive pressure.
- (8) Rotate the adjusting rod to obtain the proper pressure.

7-2. Helpful Cutting Hints

- (1) The harder the materials, the slower the cutting speed should be.

- (2) Use of cutting oil is recommended when the blade speed is higher.
- (3) To increase the feed, turn the feed screw adjustment (at left of base) counter clockwise: to decrease turn clockwise. Do not adjust more than one turn at a time.

7-3. Blade Speeds

When using your band saw always change the blade speed to best suit the material being cut. The material cutting chart gives suggested setting for several materials.

MATERIAL CUTTING CHART

Material	Speed		Belt Groove Used	
	50Hz	60Hz	Motor Pulley	Saw Pulley
Tool, Stainless or Alloy Steel, Bearing Bronzes	20 MPM	24 MPM	Small	Large
Mild Steel, Hard Brass or Bronze	29 MPM	37 MPM	Medium	Medium
Soft Brass, Aluminum, other light materials	50 MPM	61 MPM	Large	Small

7-4. Blade selection

- (1) A 14-tooth per inch, general-use blade is furnished with this metal cutting band saw. Additional blades in 6, 10, 14 and 18 tooth sizes are available.
- (2) The choice of blade pitch is governed by the thickness of the work to be cut.
- (3) The thinner work-piece. The more teeth advised.
- (4) If the teeth of the blade are too far apart can result in severe damage to the work-piece and to the blade.

7-5. Changing blades

Raise saw head to vertical position. Loosen blade tension adjustable knob sufficiently to allow the saw blade to slip off the wheels.

Install the new blade as follows:

- (1) Place the blade in between each of guide bearing.
- (2) Slip the blade around the motor pulley (bottom) with the left hand and hold in position.
- (3) Hold the blade taut against the motor pulley by pulling the blade upward with the right hand which be placed at the top of the blade.
- (4) Remove left hand from bottom pulley and place it at the top side of the blade to continue the application on the upward pull on the blade.

- (5) Remove right hand from blade and adjust the position of the top pulley to permit left hand to slip the blade around the pulley using the thumb, index and little finger as guides.
- (6) Adjust the blade tension knob clockwise until it is just right enough, so no blade slippage occurs. Do not tighten excessively.
- (7) Place 2-3 drops of oil on the blade.
- (8) Replace the blade guard.

7-6. Starting Saw

- (1) Never operate saw without blade guards in place.
- (2) Be sure the blade is not in contact with the work when the motor is started.
- (3) Start the motor, allow the saw to come to full speed.
- (4) Do not drop or force the head provide the cutting force by letting the head down slowly into the work.
- (5) Proper feed is important, excessive pressure can break the blade or stall the saw. Insufficient pressure dulls the blade rapidly.
- (6) Never use a new blade to complete previously started cut.
- (7) Do not start cutting on the sharp corners.

Switch button function description

A → Stop button

B → Start button

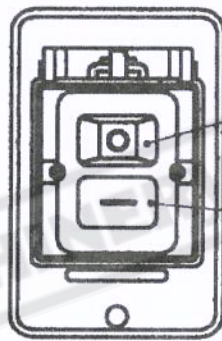

ON-OFF Switch

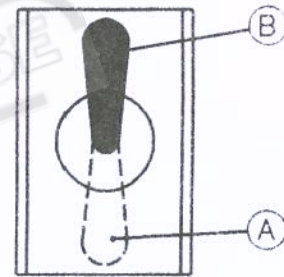

Toggle Switch

7-7. TELLTALE CHIPS

Chips are the best indicator of correct feed force. Monitor chip information and adjust feed accordingly.

Thin or powdered chips – increase feed rate or reduce band speed.

Burned heavy chips – reduce feed rate and/or band speed.

Curly silvery and warm chips – optimum feed rate and band speed.

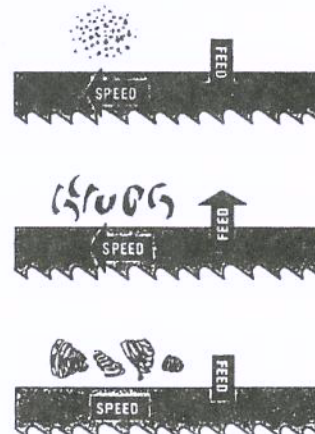

8. MACHINE ELEMENTS ADJUSTMENT

8-1. Vertical Adjustment of the Blade Wheels

- (1) Remove the blade guards.
- (2) Turn the blade tension adjustable knob counterclockwise so that the blade might loosen a little.
- (3) Adjust the hex-hole screw in the hole of slide block until the front blade wheel rises backward a little so that the blade will be kept in position.
- (4) Tighten the blade tension adjustable knob until the blade obtains the proper tension.
- (5) Check the tracking by turning on the machine. If the blade slides forward, go back to step 4 until the rear blade touches the flange of blade wheel.
- (6) Turn off power to the machine.
- (7) Replace the blade guards.

8-2. Blade Guide Bearing Adjustment

Attention: This is the most important adjustment on your saw. It is impossible to get satisfactory work from your saw if the blade guides are not properly adjusted.

Note: There should be from .000 (just touching) .001 clearance between the blade and guide bearing. To obtain this clearance adjust as follows:

- (1) Each of two guide bearing is mounted to an eccentric bushing and can be adjusted.
- (2) Loosen the nut while holding the bolt with an alien wrench.
- (3) Position the eccentric by turning the bolt to the desired position of clearance. (The blade will be just completely vertical while it is cutting.)
- (4) Tighten the nut, and the adjustable shaft of the guide bearing is fixed.
- (5) Adjust the second blade guide bearing in the same manner.

8-3. Blade Tension Adjustment:

- (1) Make sure the motor is shut off.
- (2) Press the blade lightly with the left hand, make the rear blade against the flange of blade wheel and feel the blade tension that the blade does not come off from the wheel.
- (3) Adjust the blade tension adjustable knob with the right hand until the blade obtains the proper tension.

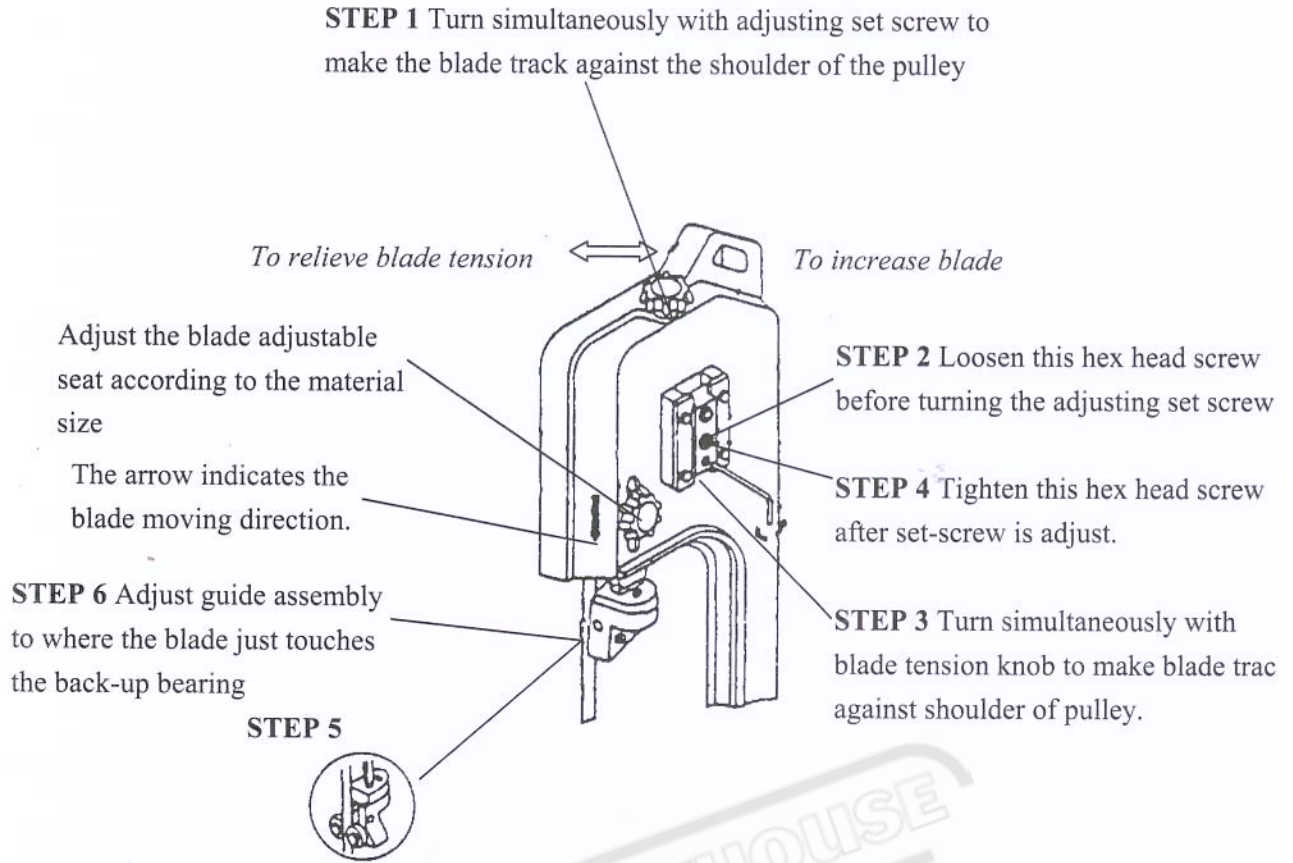
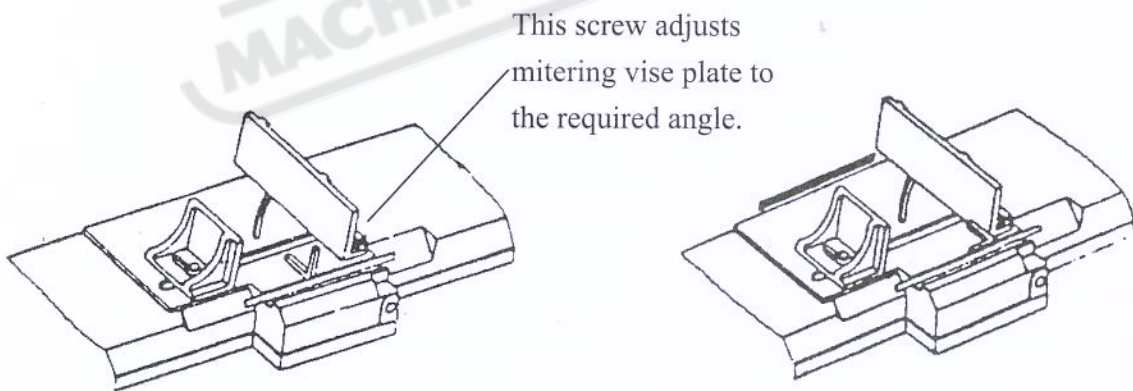

Fig.1



Place the right angle gauge on the bed to adjust the blade vertical angle .If blade is not vertical to right angle gauge adjust the blade adjustable seat according to Fig. 1

When blade is vertical the bed, adjust the mitering vise plate to right angle on the basis o right angle gauge against the blade. (As above, the clamping face of mitering vise must be on : line with the scale.)

Note: Please, refer to the instruction manual when you meet troubles while operating.

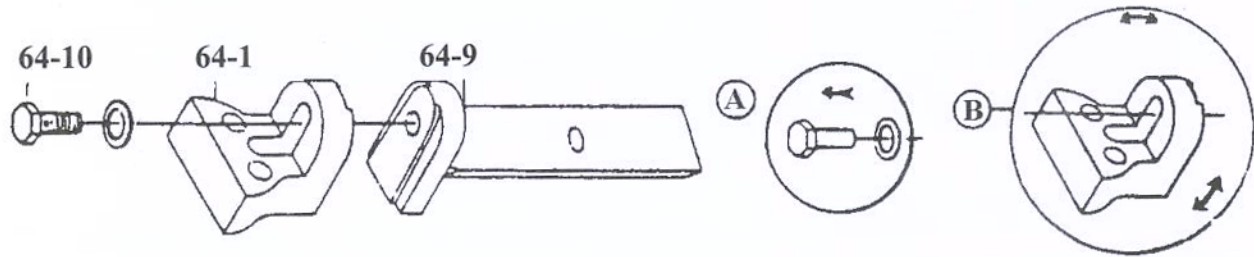

Method of adjusting blade:

- A. Loosen the screw # 64-10.
- B. Adjust the blade adjustable seat # 64-1 to make the blade vertical to bed.
- C. Place the square on the bed to check if the blade is vertical, if not, repeat the process A to C.
- D. Tighten the screw # 64-10.

9. MAINTAINING

That's easier to keep machine in good condition or best performance by means of maintaining it at any time than remedy it after it is out of order.

(1) Daily Maintenance (by operator)

- (a) Fill the lubricant before starting machine everyday.
- (b) If the temperature of spindle caused over-heating or strange noise, stop machine immediately to check it for keeping accurate performance.
- (c) Keep work area clean; release vise, cutter, work-piece from table; switch off power source; take chip or dust away from machine and follow instructions lubrication or coating rust proof oil before leaving.

(2) Weekly Maintenance

- (a) Clean and coat the leading screw with oil.
- (b) Check to see if sliding surface and turning parts lack of lubricant. If the lubricant is insufficient, fill it.

(3) Monthly Maintenance

- (a) Check if the fixed portion had been loose.
- (b) Lubricate bearing, worm, and worm shaft to avoid the wearing.

(4) Yearly Maintenance

- (a) Adjust table to horizontal position for maintenance of accuracy.
- (b) Check electric cord, plug, switches, at least once a year to avoid loosening or wearing.

10. LUBRICATING

- (1) Be sure to clean. The band saw after operation. And coat this machine with rust-less oil.
- (2) Using SAE-30 oil to lubricate the components.
- (3) Lubricate the vise lead screw as heeded.
- (4) The drive gears are in oil bath, they will not require a lubricant change more often than once a year, unless a leak or over-heat occur.

11. TROUBLE SHOOTING

Symptom	Possible Cause(s)	Corrective Action
Excessive Blade Breakage	<ol style="list-style-type: none"> 1. Materials loosen in vise. 2. Incorrect speed or feed 3. Blade teeth spacing too large 4. Material too coarse 5. Incorrect blade tension 6. Teeth in contact with material before saw is started 7. Blade rubs on wheel flange 8. Miss-aligned guide bearings 9. Blade too thick 10. Cracking at weld 	<ol style="list-style-type: none"> 1. Clamp work securely 2. Adjust speed or feed 3. Replace with a small teeth spacing blade 4. Use a blade of slow speed and small teeth spacing 5. Adjust to where blade just does not slip on wheel 6. Place blade in contact with work after motor is started 7. Adjust wheel alignment 8. Adjust guide bearings 9. Use thinner blade 10. Weld again, note the weld skill.
Premature Blade Dulling	<ol style="list-style-type: none"> 1. Teeth too coarse 2. Too much speed 3. Inadequate feed pressure 4. Hard spots or scale on material 5. Work hardening of material. 6. Blade twist 7. Insufficient blade 8. Blade slide 	<ol style="list-style-type: none"> 1. Use finer teeth 2. Decrease speed 3. Decrease spring tension on side of saw 4. Reduce speed, increase feed pressure 5. Increase feed pressure by reducing spring tension 6. Replace with a new blade, and adjust blade tension 7. Tighten blade tension adjustable knob 8. Tighten blade tension

Unusual Wear on Side/Back of Blade	<ol style="list-style-type: none"> 1. Blade guides worn. 2. Blade guide bearings not adjust properly 3. Blade guide bearing bracket is loose 	<ol style="list-style-type: none"> 1. Replace. 2. Adjust as per operators manual 3. Tighten.
Teeth Ripping from Blade.	<ol style="list-style-type: none"> 1. Tooth too coarse for work 2. Too heavy pressure; too slow speed. 3. Vibrating work-piece. 4. Gullets loading 	<ol style="list-style-type: none"> 1. Use finer tooth blade. 2. Decrease pressure, increase speed 3. Clamp work piece securely 4. Use coarser tooth blade or brush to remove chips.
Motor running too hot	<ol style="list-style-type: none"> 1. Blade tension too high. 2. Drive belt tension too high. 3. Blade is too coarse for work 4. Blade is too fine for work 5. Gears aligned improperly 6. Gears need lubrication 7. Cut is binding blade 	<ol style="list-style-type: none"> 1. Reduce tension on blade. 2. Reduce tension on drive belt. 3. Use finer blade. 4. Use coarse blade. 5. Adjust gears so that worm is in center of gear. 6. Check oil path. 7. Decrease reed anti speed
Bad Cuts (Crooked)	<ol style="list-style-type: none"> 1. Feed pressure too great. 2. Guide bearings not adjusted properly 3. Inadequate blade tension. 4. Dull blade. 5. Speed incorrect. 6. Blade guides spaced out too much 7. Blade guide assembly loose 8. Blade truck too far away from wheel flanges 	<ol style="list-style-type: none"> 1. Reduce pressure by increasing spring tension on side of saw 2. Adjust guide bearing, the clearance can not greater than 0.001. 3. Increase blade tension by adjust blade tension 4. Replace blade 5. Adjust speed 6. Adjust guides space. 7. Tighten 8. Re-track blade according to operating instructions.
Bad Cuts (Rough)	<ol style="list-style-type: none"> 1. Too much speed or feed 2. Blade is too coarse 3. Blade tension loose 	<ol style="list-style-type: none"> 1. Decrease speed or feed. 2. Replace with finer blade. 3. Adjust blade tension.
Blade is twisting	<ol style="list-style-type: none"> 1. Cut is binding blade. 2. Too much blade tension. 	<ol style="list-style-type: none"> 1. Decrease reed pressure. 2. Decrease blade tension.

12.CIRCUIT DIAGRAM

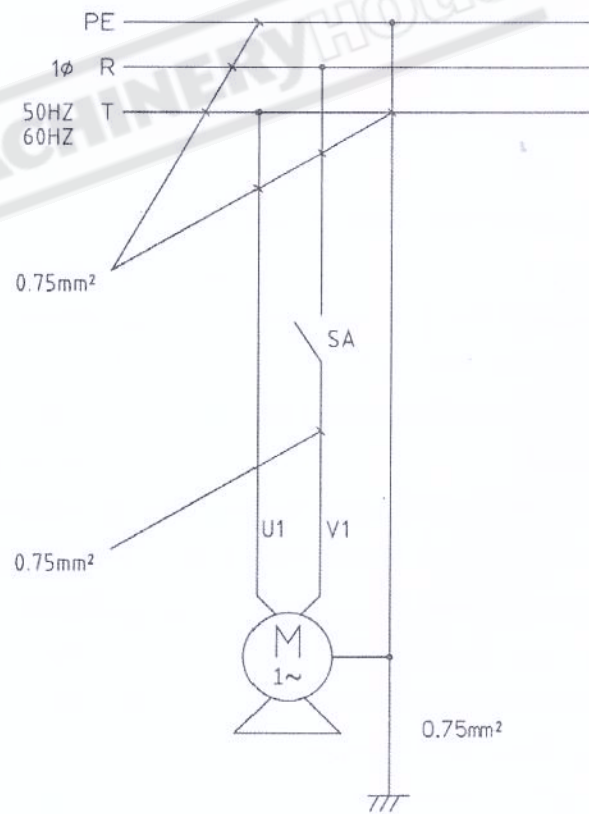
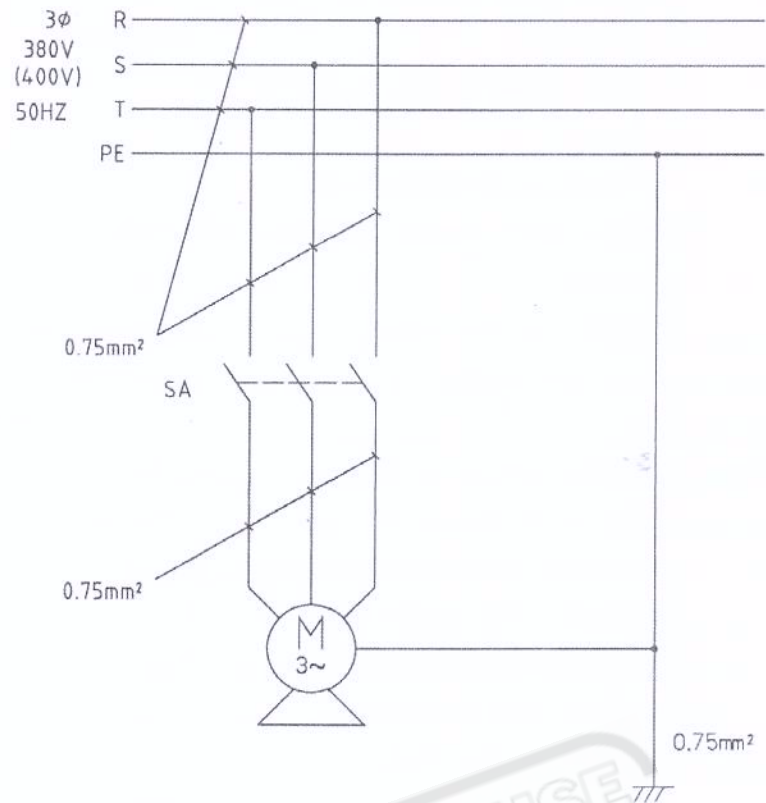

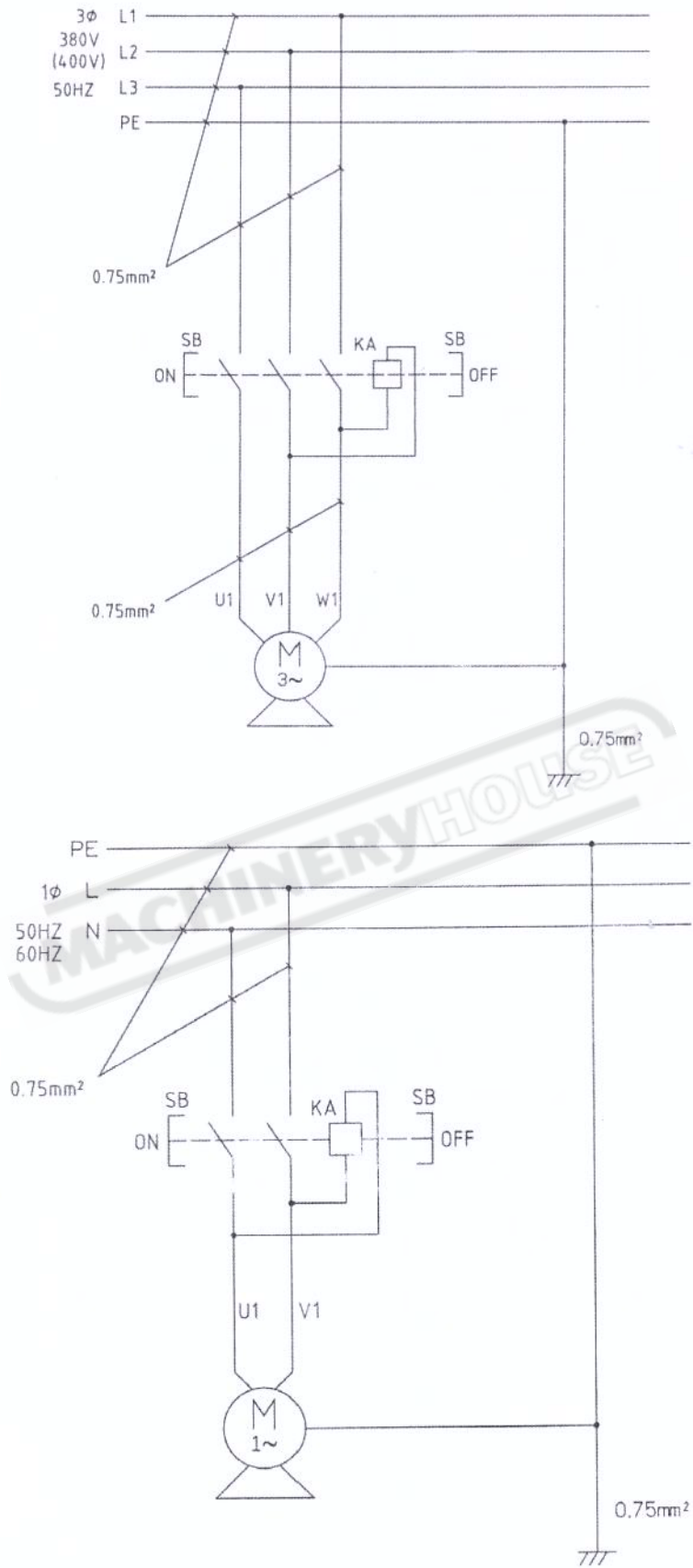

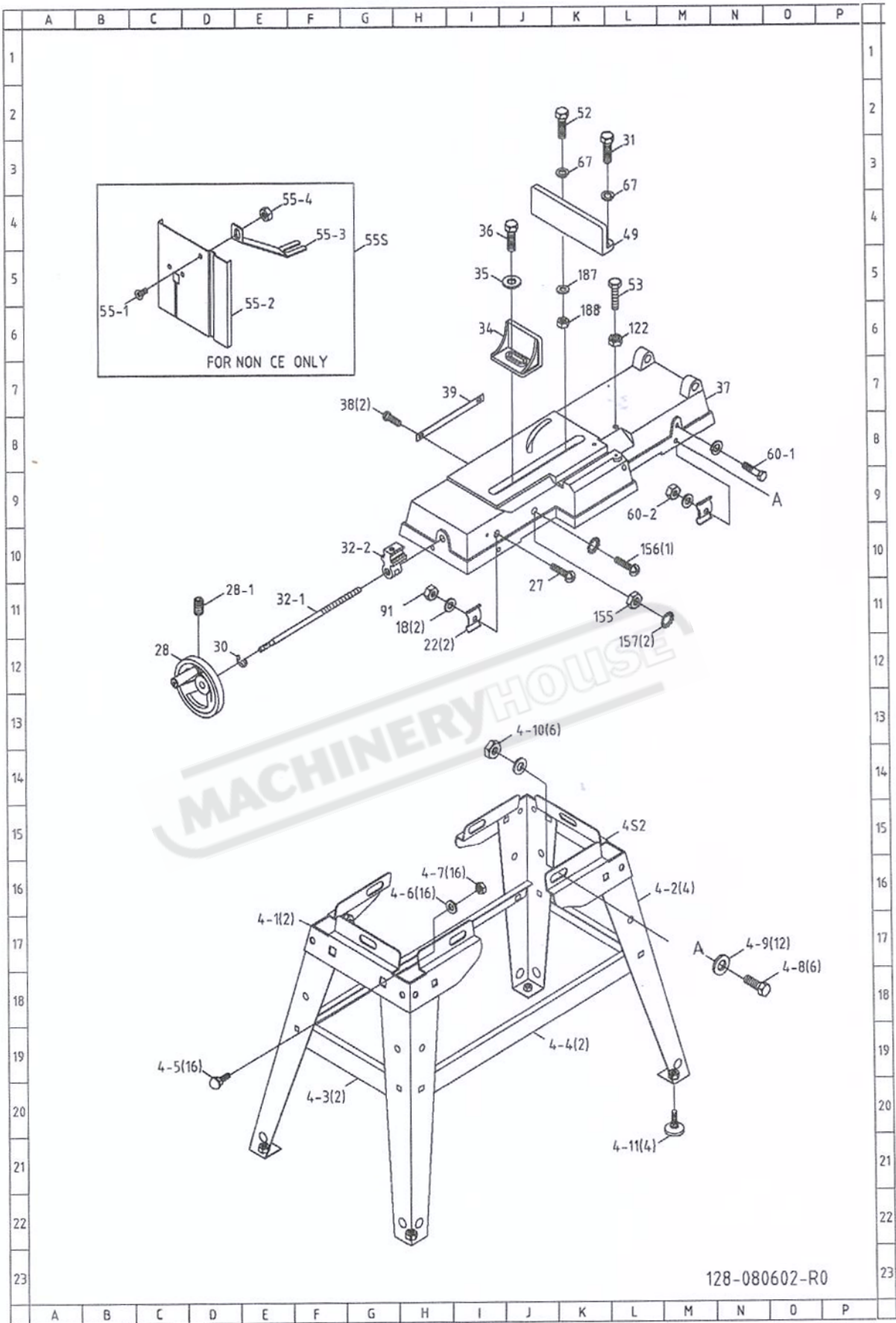

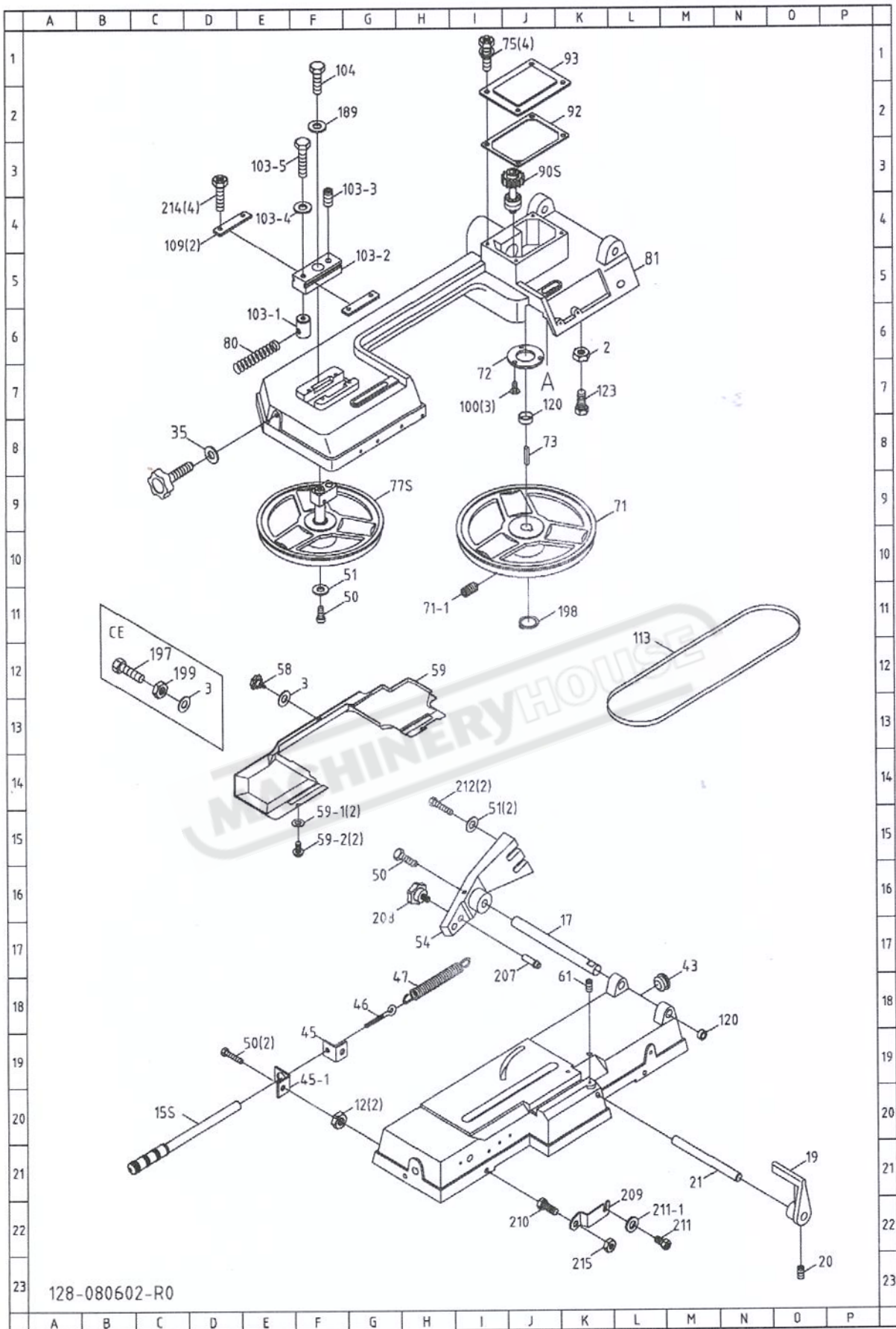

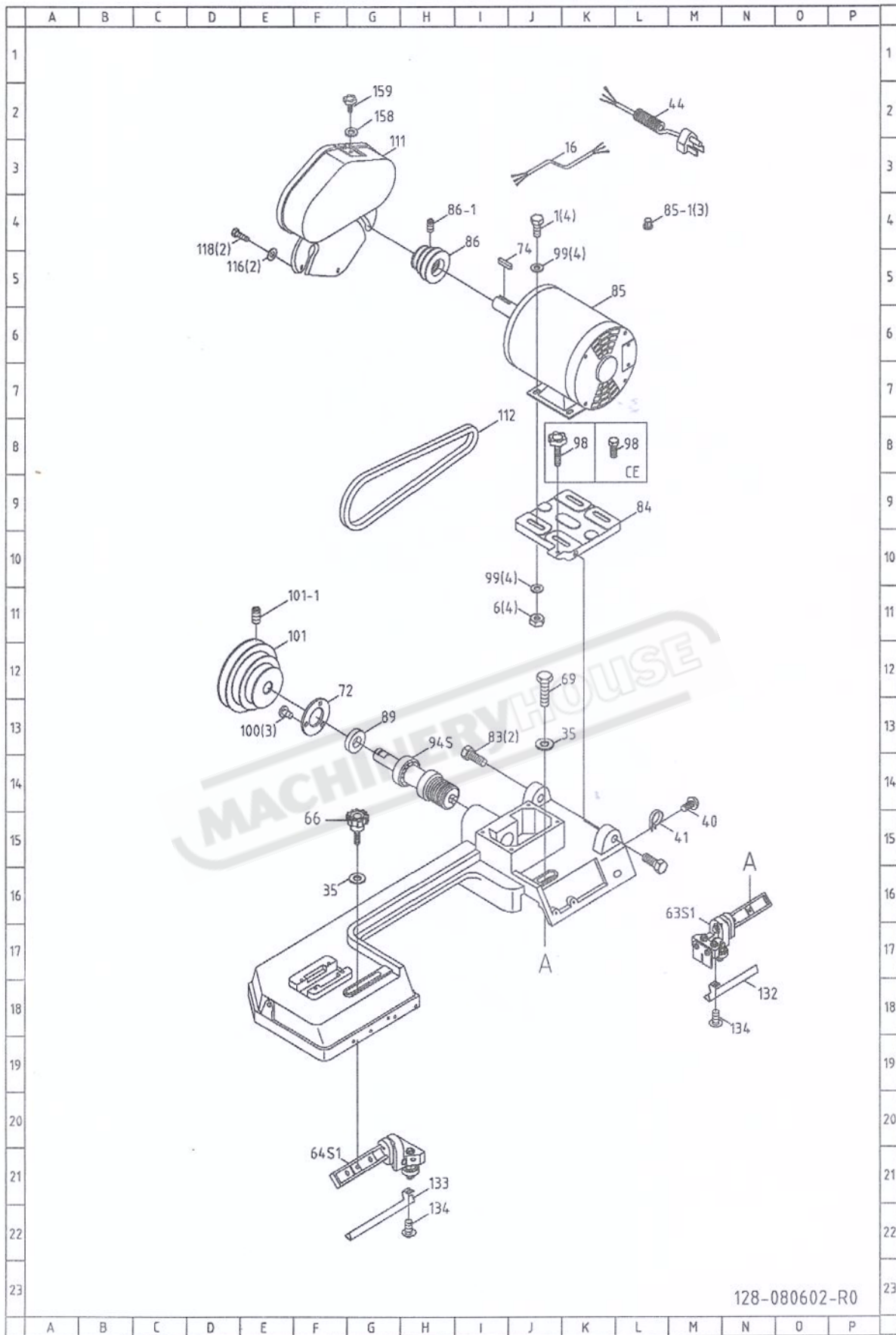

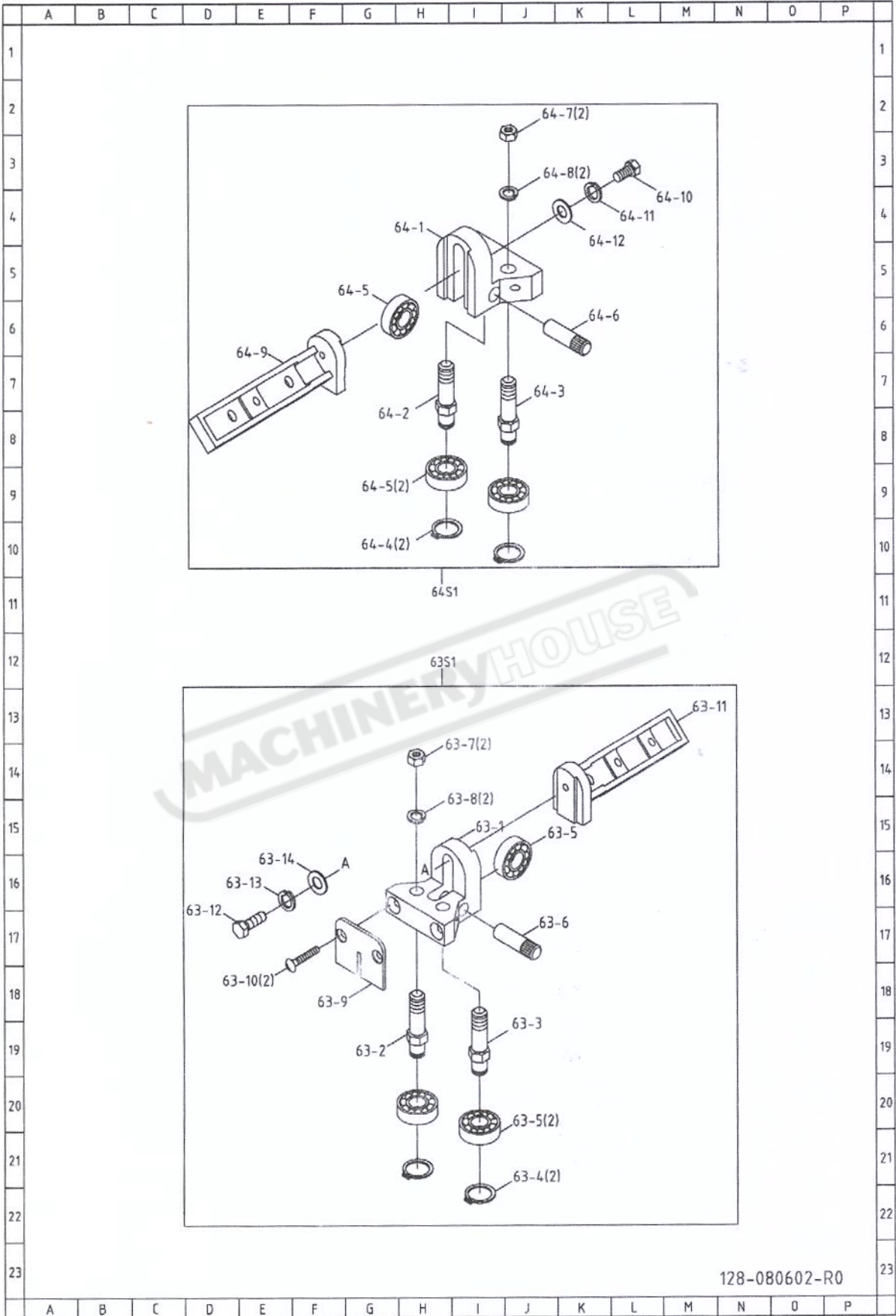

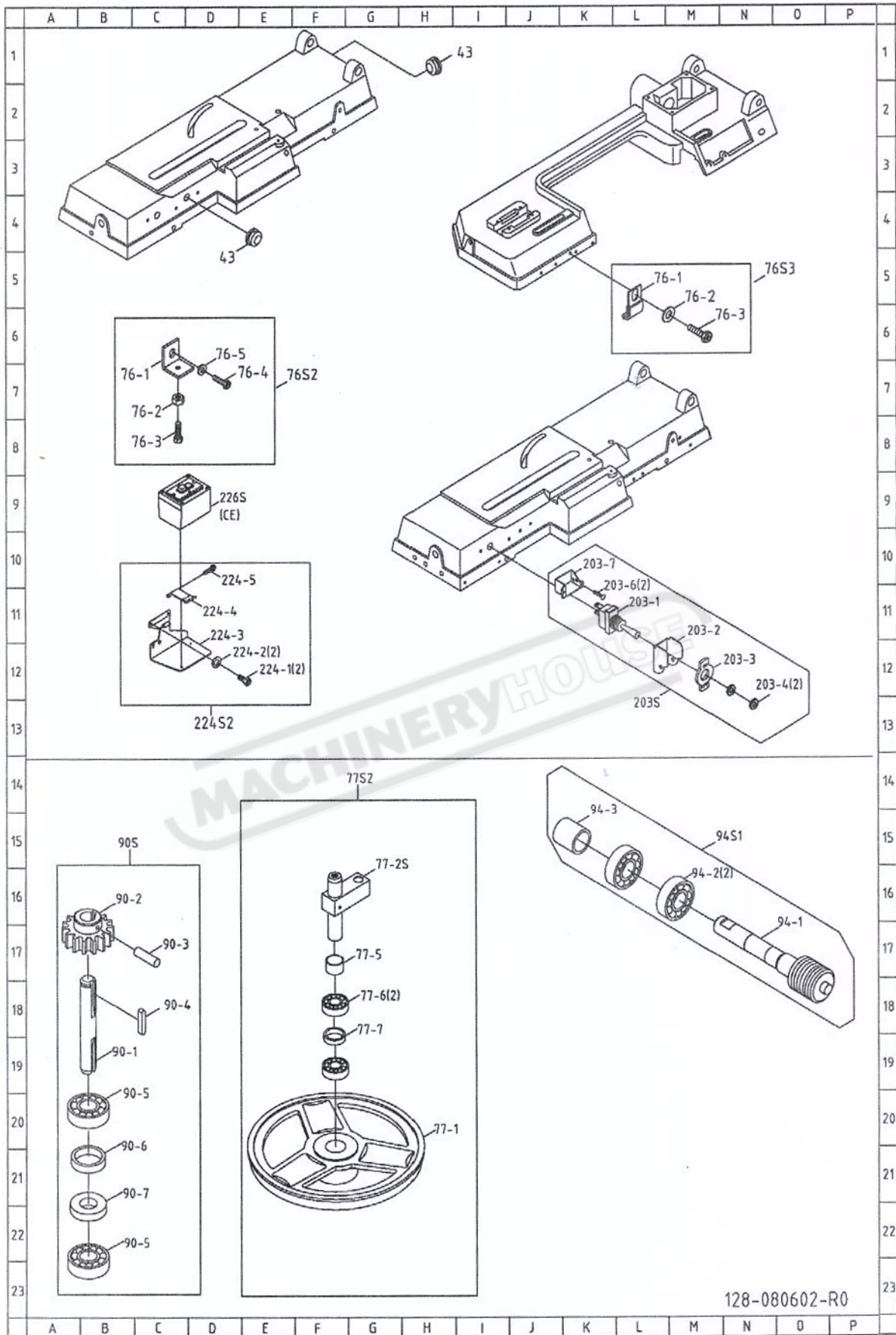

PARTS LIST
MODEL NO. 128

CODE NO	PART NO	DESCRIPTION	SPECIFICATION	QTY	NOTE
1	S022	Hex. Head Screw	5/16X3/4	4	
2	N003	Hexagon Nut	1/4"	1	
3	W004	Washer	1/4"x19xt1.5	1	
4S2	3004FS	Stand Complete Assembly		1	
4-1	3004F-1	Cross Brace		2	
4-2	3004F-2	Stand Leg		4	
4-3	3004F-3	Leg		2	
4-4	3004F-4	Leg		2	
4-5	3206	Screw	5/16"x3/4"L	16	
4-6	W016	Washer	5/16"x23xt2	16	
4-7	N007	Hex. Nut	5/16"	16	
4-8	S017	Hex. Head Screw	5/16"x1"L	6	
4-9	W016	Washer	5/16"x23xt2	12	
4-10	N007	Hex. Nut	5/16"	6	
4-11	32421E-3	Coaster of Stand	3/8"	4	
6	N007	Hex. Nut	5/16"	4	
15S	3015S	Adjust Tension Rod		1	
16	E158412	Motor Cable		1	
17	3017	Pivoting Rod		1	
18	W205	Spring Washer	5/16"	2	
19	3019	Distance Set Bracket		1	
20	S018	Hex. Head Screw	5/16"x5/16"L	1	
21	3021	Stock Stop Rod	φ1/2"x216L	1	
22	3022-1	Wire Relief Retainer		2	
27	S017	Hex. Head Screw	5/16"x1"L	2	
28	3028B	Hand wheel		1	
30	HE013	E Retaining Ring	E10	1	
31	S017	Hex. Head Screw	5/16"x1"L	1	
32S	3032S	Lead Screw		1	
32-1	3032	Lead Screw		1	
32-2	3033	Vise Nut		1	
34	3034	Movable Vise Plate		1	
35	W011	Washer	3/8"x27xt3	4	
36	S013	Hex. Head Screw	3/8"x1-1/4"L	1	
37	3037A	Swivel Base		1	
38	S708	Cross Round Head Screw	3/16"x3/8"L	2	
39	3039B	Scale		1	
40	S708	Cross Round Head Screw	3/16"X3/8L	1	
41	HI107	Wire Ring	3/8"	1	
43	3043	Wire protector		1	
44	195314	Power cable		1	
45	3045	Spring Handle Bracket		1	
45-1	3045-1	Spring Handle Bracket		1	
46	3046	Spring Adjusting Screw		1	
47	3047	Spring		1	
49	3049	Movable Vise Plate		1	
50	S022	Hex. Head Screw	5/16"x3/4"L	4	
51	W018	Washer	5/16"x23xt3	3	

PARTS LIST
MODEL NO. 128

CODE NO	PART NO	DESCRIPTION	SPECIFICATION	QTY	NOT
52	S019	Hex. Head Screw	5/16"x1-1/2"L	1	
53	S001	Hex. Head Screw	7/16"x2"L	1	FOR CE ON
54	3054B	Pivot		1	
55S	3055AS	Vertical Saw Table (Optional)		1	FOR NON C
55-1	S301	Flat Cross Head Screw	1/4"x3/8"L	1	FOR NON C
55-2	3055A	Vertical Saw Table (Optional)		1	FOR NON C
55-3	3056-2	Table Supporting Plate		1	FOR NON C
55-4	N003	Hexagon nut	1/4"	1	FOR NON C
58	3058	Plum handle Screw		1	
59	3059B	Blade Back Safety Cover		1	
59-1	W004	Washer	1/4"×19×t1.5	2	
59-2	S704	Cross Round Head Screw	1/4"×3/8"L	2	
61	S610	Hex.Socket Headless Screw	5/16"x5/16"L	1	
63S1	3064SA1	Blade Adjustable Assembly (Rear)		1	
63-1	3064	Blade Adjustable (Rear)		1	
63-2	3062	Bearing Shaft		1	
63-3	3062-1	Guide Pivot (Right)		1	
63-4	C100	C-Retainer Ring		2	
63-5	CA6000ZZ	Bearing	6000ZZ	3	
63-6	3063	Bearing Pin	φ10x36L	1	
63-7	N006	Hex. Nut	3/8"UNF	2	
63-8	W204	Spring Washer	φ3/8"	2	
63-9	3069	Deflector Plate		1	
63-10	S302	Flat Cross Head Screw	1/4"x3/8"L	2	
63-11	32405	Adjustable Bracket (Right)		1	
63-12	S023	Hex. Head Screw	5/16"x1-1/4"L	1	
63-13	W205	Spring Washer	φ5/16"	1	
63-14	W016	Washer	5/16"x23xt2	1	
64S1	3064SB1	Adjustable Bracket Assembly (Right)		1	
64-1	3064-1	Blade Adjustable (Front)		1	
64-2	3062	Bearing Shaft		1	
64-3	3062-1	Guide Pivot (Left)		1	
64-4	HCS01	C-Retainer Ring		2	
64-5	CA6000ZZ	Bearing	6000ZZ	3	
64-6	3063	Bearing Pin	φ10x36L	1	
64-7	N006	Hex. Nut	3/8"UNF	2	
64-8	W204	Spring Washer	φ3/8"	2	
64-9	32406	Adjustable Bracket (Left)		1	
64-10	S023	Hex. Head Screw	5/16"x1-1/4"L	1	
64-11	W205	Spring Washer	φ5/16"	1	
64-12	W016	Washer	5/16"x23xt2	1	
66	3066-3	Blade Adjustable Knob	3/8"-16UNCx31L	1	
67	W205	Spring Washer	5/16"	2	
69	S013	Hex. Head Screw	3/8"x1-1/4"L	1	
71	3071	Blade Wheel (Front)		1	
71-1	S610	Hex. Socker Headless Screw	5/16"x5/16"L	1	
72	3072-2	Bearing Cover		2	
73	HK109	Key	5x5x25L	1	

PARTS LIST
MODEL NO. 128

CODE NO	PART NO	DESCRIPTION	SPECIFICATION	QTY	NOTE
74	HK109	Key	5x5x30L	1	
75	S202	Hex. Head Screw	1/4"x5/8"L	4	
76S2	3076-2S	Switch Cut Off Tip(For CE Only)		1	FOR CE ONLY
76-1	3076-2	Switch Cut Off Tip(For CE Only)		1	FOR CE ONLY
76-2	N007	Hex. Nut	5/16"	1	FOR CE ONLY
76-3	S017	Hex. Head Screw	5/16"x1"L	1	FOR CE ONLY
76-4	S203	Hex. Head Screw	1/4"x3/8"L	1	FOR CE ONLY
76-5	W004	Washer	1/4"×16t×1.5	1	FOR CE ONLY
76S3	3076S	Switch Cut Off Tip(For CE Only)		1	
76-1	3076	Switch Cut Off Tip		1	
76-2	W004	Washer	1/4"x16xt1.5	1	
76-3	S202	Hex. Head Screw	1/4"x5/8"L	1	
77S2	3077S-1	Blade Wheel Assembly (Rear)		1	
77-1	3077-1	Blade Wheel (Rear)		1	
77-2S	3106S	Blade Wheel Shaft Assembly		1	
	3106	Sliding Plate Draw Block		1	
	HP013	Pin	ψ4*20L	1	
77-5	3119-1	Blade Wheel Bushing		1	
77-6	CA6202ZZ	Ball Bearing (6202ZZ)	6202ZZ	2	
77-7	3126	Bushing		1	
79	3079E	Blade tension adjustable knob	3/8"-16UNCx105L	1	
80	3080	Spring		1	
81	3081D	Body Frame		1	
83	S002	Hex. Head Screw	1/2"x1-1/2"L	2	
84	3084-1	Motor Mount Plate		1	
85		Motor		1	
85-1	ET2906	Wire Guard	Y2	3	
86	3086A	Motor Pulley		1	
86-1	S644	Hex. Socker Headless Screw	5/16"x1/4"L	1	
89	3089	Oil Seal	TC15x35x7	1	
90S	3091JS	Transmission Gear Assembly		1	
90-1	3090	Transmission Wheel Shaft		1	
90-2	3091J	Transmission Gear		1	
90-3	P005	Pin	φ4x22L	1	
90-4	HK109	Key	5x5x25L	1	
90-5	CA6202ZZ	Ball Bearing (6202ZZ)	6202ZZ	2	
90-6	3088	Bushing		1	
90-7	3089	Oil Seal	TC15x35x7	1	
91	N007	Hex. Nut	5/16"	2	
92	3092	Gear Box Gasket		1	
93	3093	Gear Box Cover		1	
94S1	3094S-1	Worm Gear Shaft Assembly		1	
94-1	3094-1	Worm Gear Shaft		1	
94-2	CA6202ZZ	Ball Bearing (6202ZZ)	6202ZZ	2	
94-3	3096-1	Bearing Bushing		1	
98	3098	Plum Screw	5/16"-18UNCx45L	1	

PARTS LIST
MODEL NO. 128

CODE NO	PART NO	DESCRIPTION	SPECIFICATION	QTY	NOTE
98	S019	Hex. Head Screw	5/16"x1-1/2"L	1	FOR CE ONLY
99	W016	Washer	5/16"x23xt2	8	
100	S304	Flat head cross screw	5/32"x3/8"L	6	
101	3101-2A	Worm Gear Pulley		1	
101-1	S611	Hex. Socket Headless Screw	5/16"x5/8"L	1	
103S	3103S	Blade Tension Sliding Plate Assembly		1	
103-1	3108	Shaft Block		1	
103-2	3103	Blade Tension Sliding Plate		1	
103-3	S603	Hex. Socket Headless screw	5/16"x3/4"L	1	
103-4	W018	Washer	5/16"x23xt3	1	
103-5	S023	Hex. Head Screw	5/16"x1-1/4"L	1	
104	S017	Hex. Head Screw	5/16"x1"L	1	
109	3109	Blade Tension Sliding Guides		2	
111	110110	Motor Pulley Cover Assembly		1	
112	3112B	Belt		1	
113		Blade	0.65x12.7x1638Lx14T	1	
116	W004	Washer	1/4"x19xt1.5	2	
118	S006	Hex. Head Screw	1/4"x1/2"L	2	
120	3120	Bushing	Ø9x Ø7x7	2	
122	N010	Hexagon nut	7/16"	1	FOR CE ONLY
123	S052	Hex. Head Screw	1/4"x1"L	1	
132	3132	Safety Guard (Right)		1	
133	3132-1	Safety Guard (Left)		1	FOR CE ONLY
134	S711	Cross Round Head Screw	5/32"x1/4"L	2	FOR CE ONLY
155	N004	Hex. Nut	3/16"	1	FOR CE ONLY
156	S708	Cross Round Head Screw	3/16"x3/8"L	1	
157	W302	Star Washer	3/16"	2	
158	W004	Washer	1/4"x16xt1.5mm	1	
159	3058	Plum handle Screw	3/16"x1/2"L	1	
187	W018	Washer	5/16"x23xt3mm	1	
188	N007	Hex. Nut	5/16"	1	
189	W018	Washer	5/16"x23xt3	1	
197	S009	Hex. Head Screw	1/4"x3/4"L	1	FOR CE ONLY
198	HCS04	C-Retainer ring	S15	1	
199	N003	Hexagon nut	1/4"	1	FOR CE ONLY
203S	ET1401S	Toggle Switch	2P	1	
203-1	ET1401	Toggle Switch	2P	1	
203-2	3131B	Switch Cover		1	
203-3		Switch Indicator		1	
203-4	3131A-2	Hex. Head Screw		2	
203-6	S732	Cross Round Head Screw	3/16"x3/4"L	2	
203-7	3041-1	Electric Cord Clip		1	
207	32312	Position pin		1	
208	32310	Plum handle		1	
209	3172	Fixed Plste		1	
210	S402	Hex. Socket Head Screw	1/4"x1/2"L	1	
211	S204	Hex. Head Screw	1/4"x3/4"L	1	

PARTS LIST
MODEL NO. 128

CODE NO	PART NO	DESCRIPTION	SPECIFICATION	QTY	NOTE
211-1	W015	Washer	5/16"x12xt2	1	
212	S017	Hex. Head Screw	5/16"x1"L	2	
214	S202	Hex. Head Screw	1/4"x5/8"L	4	
215	HB812	Net	1/4"	1	
224S2	3193DS	Switch Base		1	FOR CE ONLY
224-1	S202	Cross Socker Hex. Head Screw	1/4"x3/8"L	2	FOR CE ONLY
224-2	W202	Star Washer	3/16"	2	FOR CE ONLY
224-3	3193D	Switch Base		1	FOR CE ONLY
224-4	32408C	Switch Base		1	FOR CE ONLY
224-5	HS514	Cross Round Head Screw	M4x35L	1	FOR CE ONLY
226S		Push Switch		1	FOR CE ONLY

MACHINERYHOUSE